



WITTENSTEIN

alpha

WITTENSTEIN alpha Product discontinuation

Transparency
Predictability
Optimization

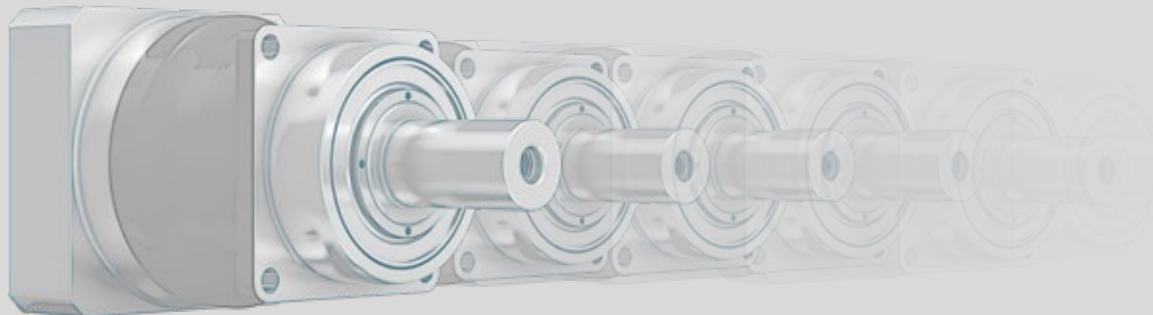

Discontinuation of products

As a leader for drive technology, WITTENSTEIN alpha is committed to firing customers' enthusiasm again and again with best-fit solutions and to presenting the company as a competent and reliable value partner.

Our aim of providing each customer with the optimal solution to meet their individual needs means product series must undergo a continuous evolution and eventually make way for successor models.

This flyer contains everything you need to know about the product discontinuation process at WITTENSTEIN alpha.

We will be happy to assist during the transition to the successor product!

Contact us:

+49 7931 493-0

info@wittenstein-alpha.de

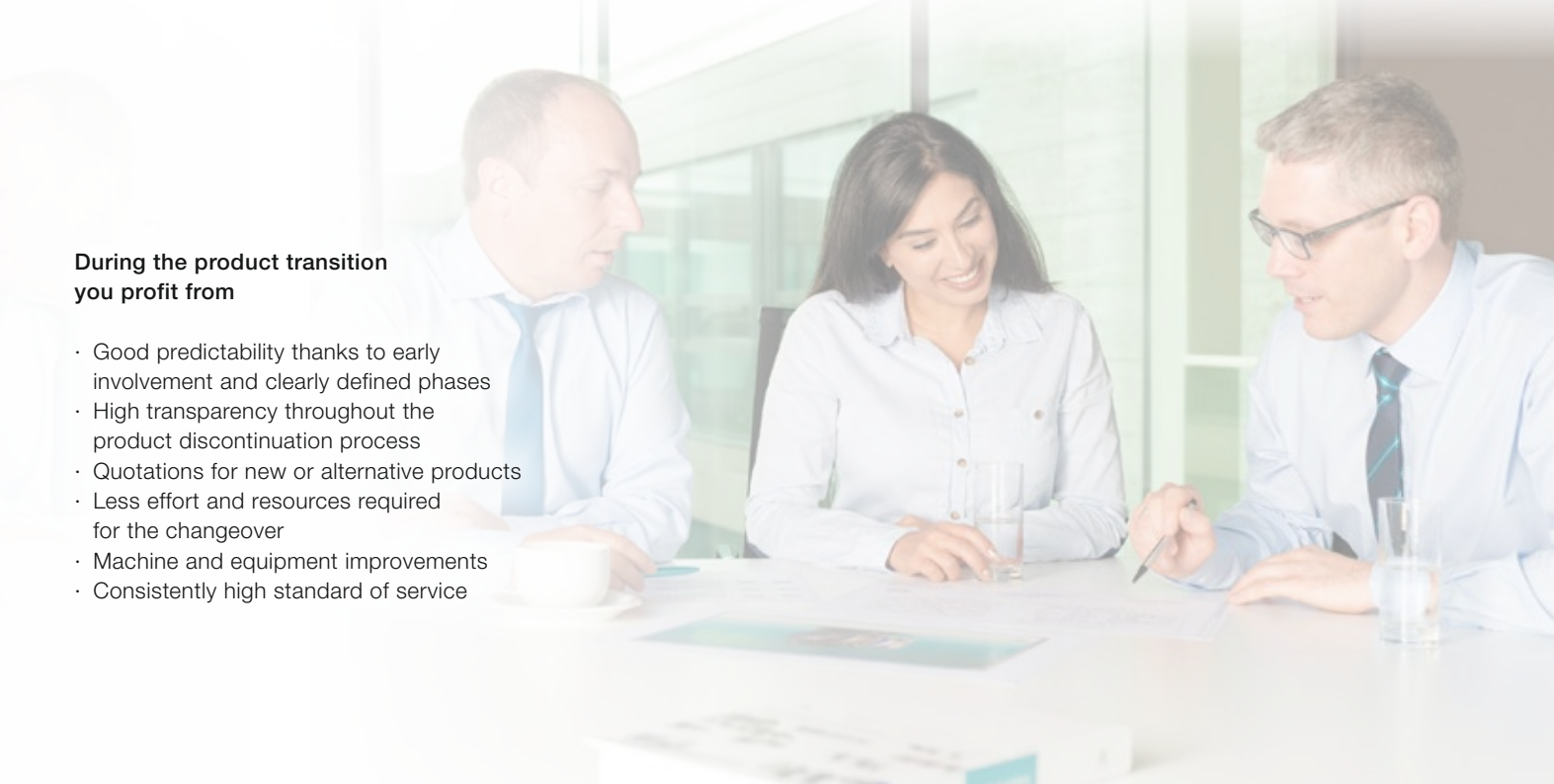
A photograph of three business professionals (two men and one woman) sitting around a table in a modern office setting, reviewing documents. The image is overlaid with a semi-transparent white box containing text. The background shows large windows and office furniture.

**During the product transition
you profit from**

- Good predictability thanks to early involvement and clearly defined phases
- High transparency throughout the product discontinuation process
- Quotations for new or alternative products
- Less effort and resources required for the changeover
- Machine and equipment improvements
- Consistently high standard of service

Phase 1

Initiation of discontinuation

You will receive written notification well in advance of plans to discontinue a product. We will keep you posted regarding new developments in documents such as quotations or order confirmations.

This timely information will enable a smooth transition to the successor product – please ask for support if necessary!

We recommend that you use the successor product for all redesigns.



1st information letter



No change in price



No change in delivery time



Usual service

Phase 2

Phase-out process

The end-of-life process begins.

A longer delivery time applies and a markup is added to the cost of ordering and delivering the products. The prices effective until now are no longer valid.

These changes do not affect existing framework agreements.



2nd information letter



Higher price



Longer delivery time



Usual service

Phase 3

Spare part supply

Phase 3 is restricted to the supply of spare parts for existing equipment. The delivery times and prices are adjusted again.

The products can no longer be ordered for new projects or redesigns.

These changes do not affect existing framework agreements.



3rd information letter



Higher price



Longer delivery time



Usual service

Phase 4

Last call

You will receive notification from us before deliveries are discontinued and given one last chance to replenish your stocks by ordering spare parts.

Delivery of the product concerned will cease after the end of this phase.

Requests for repairs will continue to be processed.



WITTENSTEIN

alpha



4th information letter



No change in price



No change in delivery time



Usual service



alpha

WITTENSTEIN alpha GmbH
Walter-Wittenstein-Str. 1
97999 Igersheim
Germany

Phone +49 7931 493-0
24h service hotline: Phone +49 7931 493-12900
speedline®: Phone +49 7931 493-10444
info@wittenstein-alpha.de

WITTENSTEIN alpha – Intelligent drive systems

www.wittenstein-alpha.de